

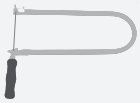

# Mobiele telefoonhouder - verstelbaar

## Flexi-telefoon

### GEREEDSCHAP:



Figuurzaag-  
beugel



liniaal & pen



boor



Kruiskop-  
schroeven-  
draaier



Houtlijm /  
alleslijm



NAAM:

KLASSE:

### ONDERDELENLIJST:

ONDERDELENLIJST:	OK✓	AFMETINGEN:	BENOEMING:	ONDERDELEN:
1 Multiplex	<input type="checkbox"/>	320 / 80 / 10 mm	Standaard	A, B
1 Houten lijstwerk	<input type="checkbox"/>	240 / 40 / 10 mm	Assen - verstelbaar	2 x C
1 Houten lijstwerk	<input type="checkbox"/>	200 / 50 / 15 mm		D, E
1 Houten lijstwerk	<input type="checkbox"/>	80 / 15 / 15 mm		F
2 Schroeven deurscharnier	<input type="checkbox"/>	M5 x 40 mm		
2 Vleugelmoeren	<input type="checkbox"/>	M5		
2 Sluitringen	<input type="checkbox"/>	M5		
6 Spax-schroeven	<input type="checkbox"/>	3,5 x 20 mm		

**1** Overzicht:

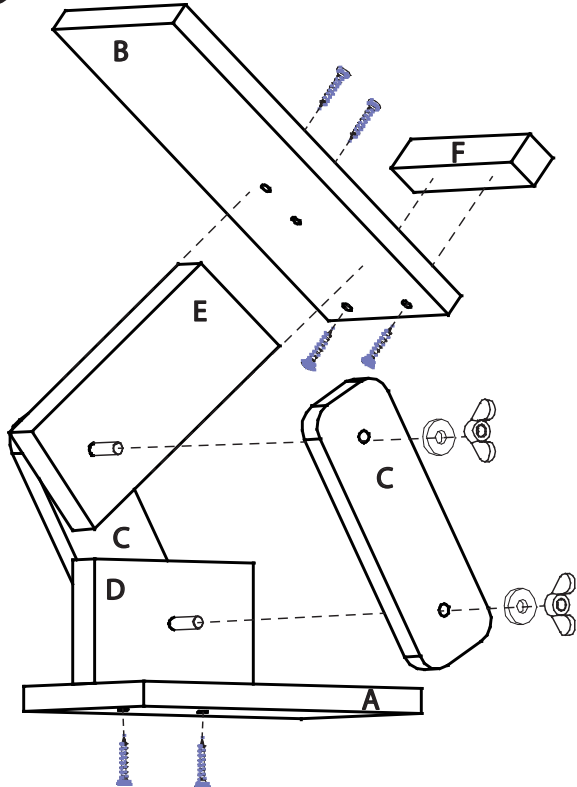

OK✓

**2** Onderdelen uitzagen en boren:



Zaag de delen (A) tot (E) uit met een zaag. (E) heeft een schuine kant. (C) heeft afgeronde hoeken. Boor vervolgens de gaten met een boor  $\varnothing$  4mm of  $\varnothing$  5mm. Lijm de houten lijst (F) op deel (B). -

OK✓

**3** Afmetingen en boorgaten:

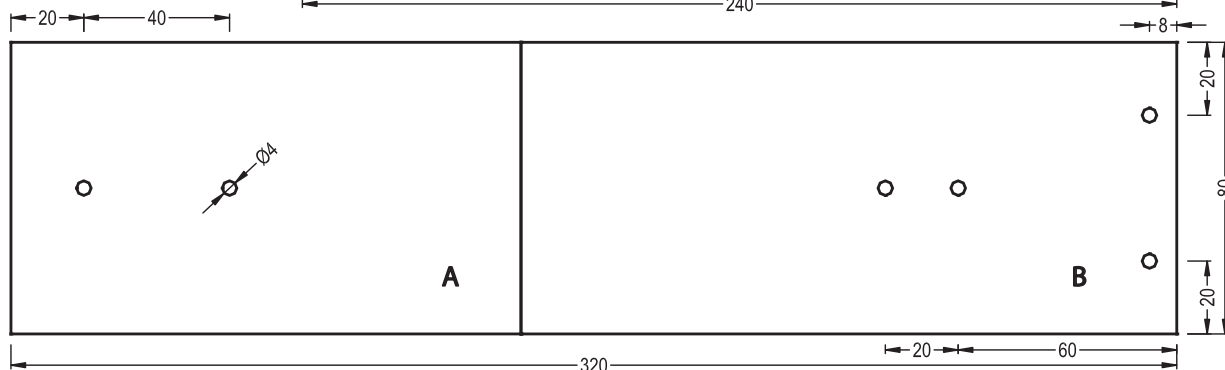
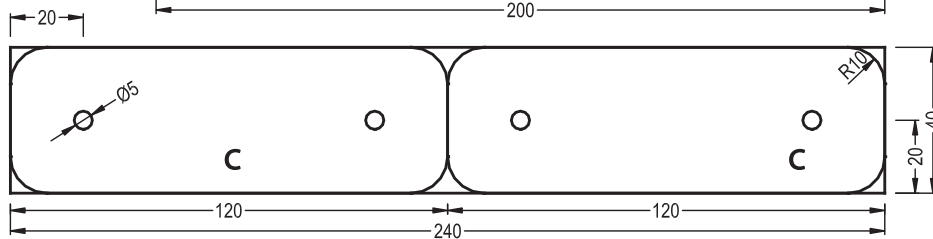
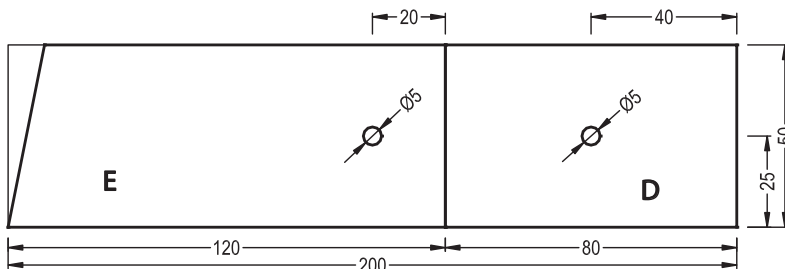
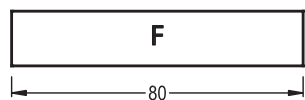

OK✓



#### 4 Montage:

Schroef en lijm nu de delen (A), (D) en de delen (B), (E), (F) aan elkaar zoals afgebeeld.

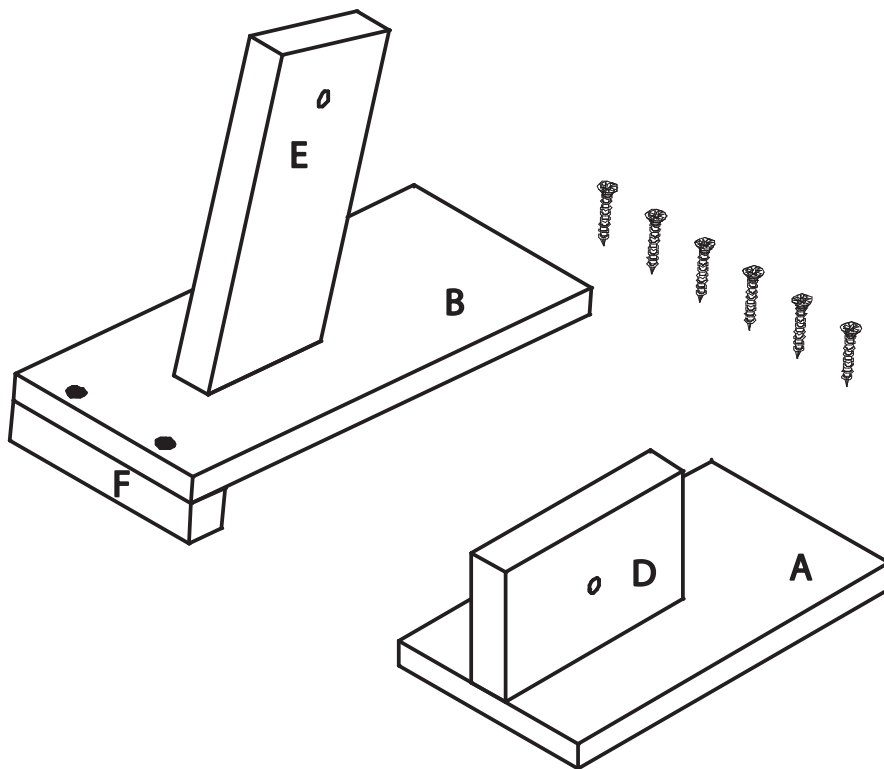

OK/

#### 5 Voltooiing

Tot slot worden de twee schroeven met ringen en vleugelmoeren door deel (C) gehaald en in de ideale positie vastgezet. Professionals demonteren nu de Flexi-Phone houder weer en verven of lakken hem. Dit beschermt het houten oppervlak permanent.

**Veel plezier en succes!**

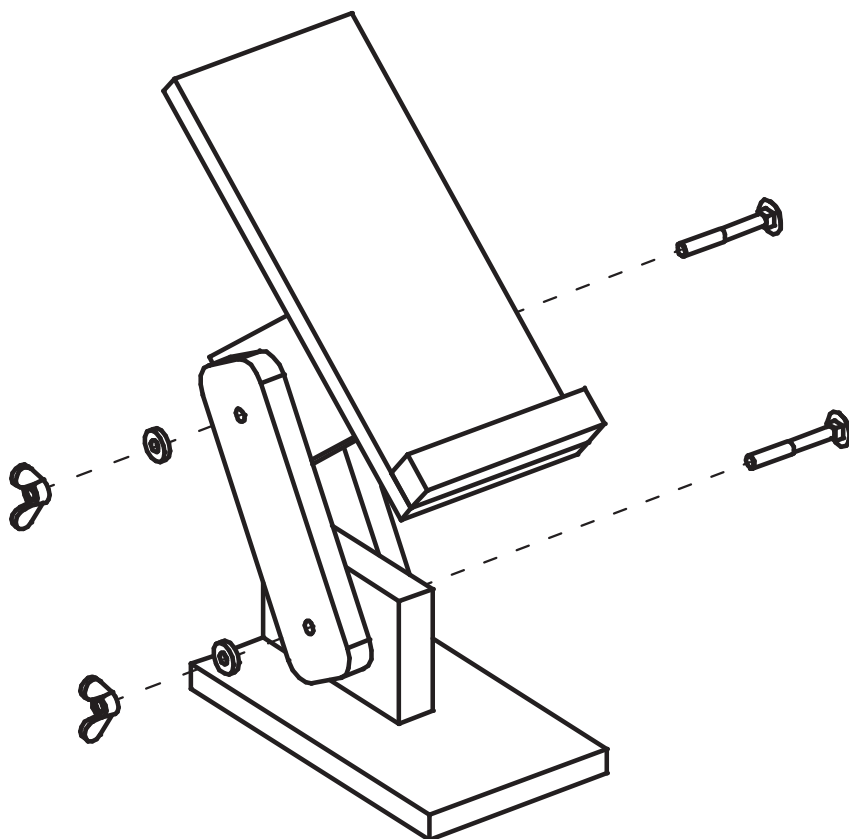

OK/